

Type: TOSAERBA

Mod.: FA-1200 • FA-1500 • FA-1800

Rev.: 01/2004

Drw: 1/4

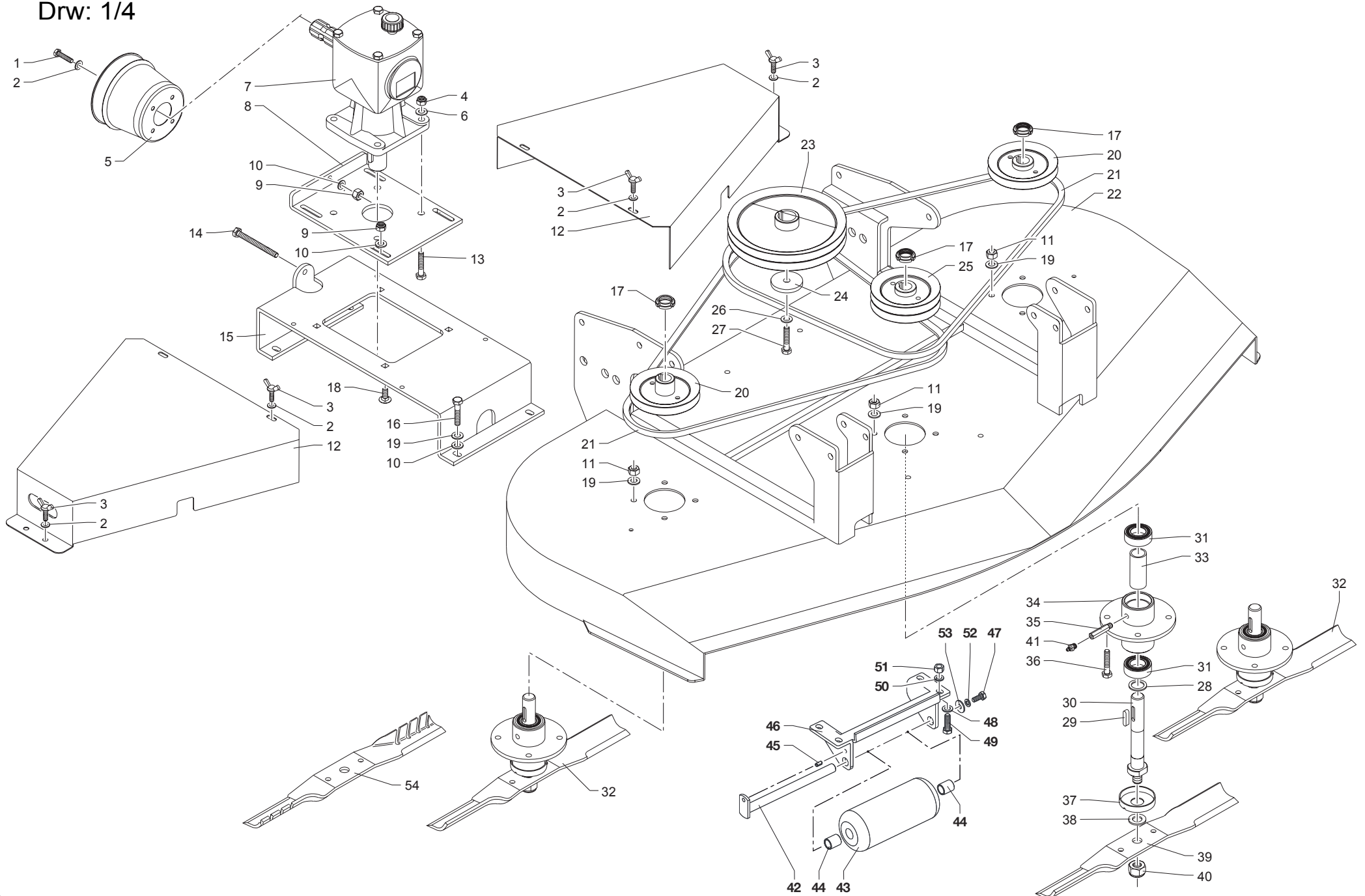

Type: TOSAERBA
Mod.: FA-1200 • FA-1500 • FA-1800
Rev.: 01/2004
Drw: 2/4

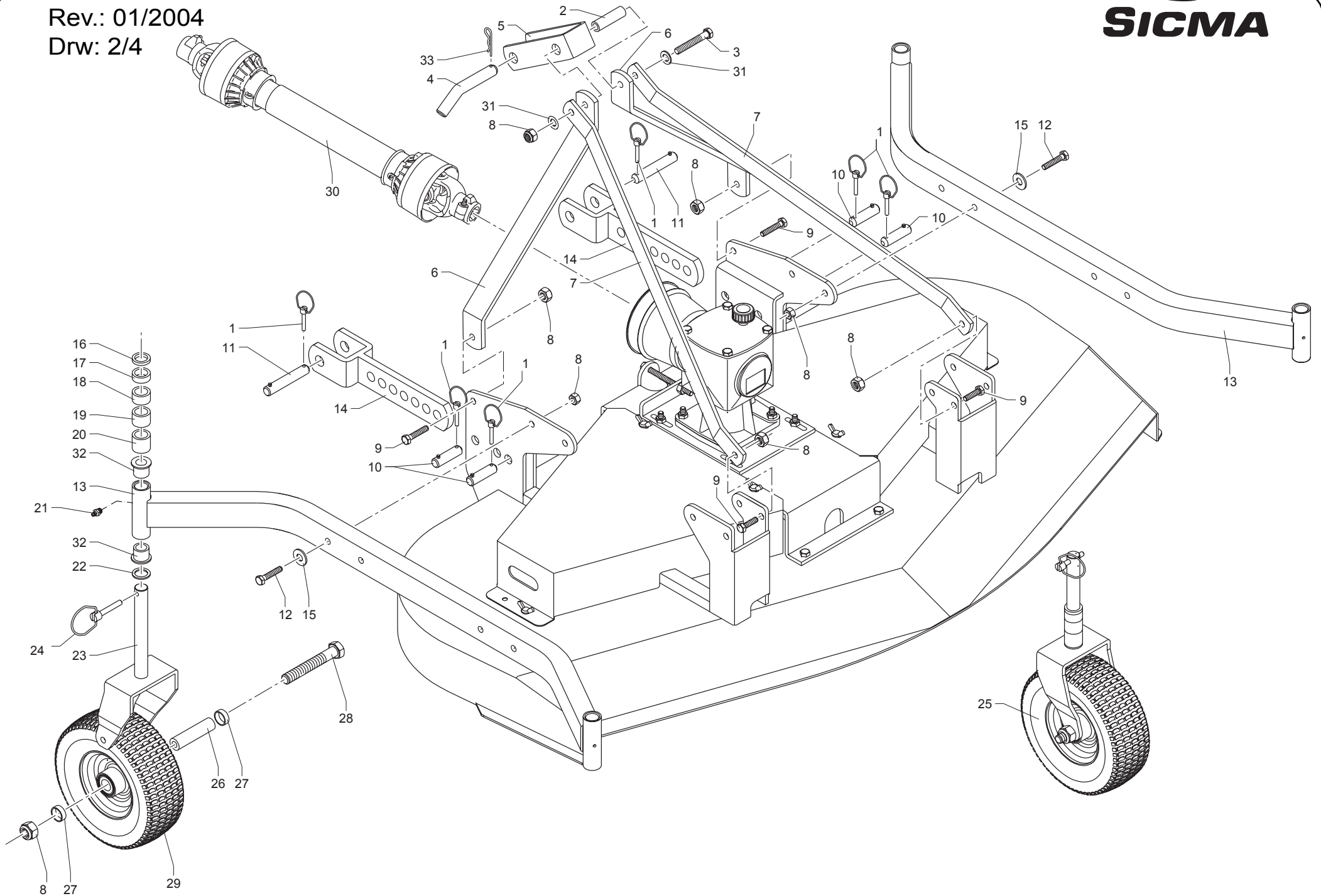

Type: TOSAERBA
Mod.: FA-1200 • FA-1500 • FA-1800
Rev.: 01/2004
Drw: 3/4

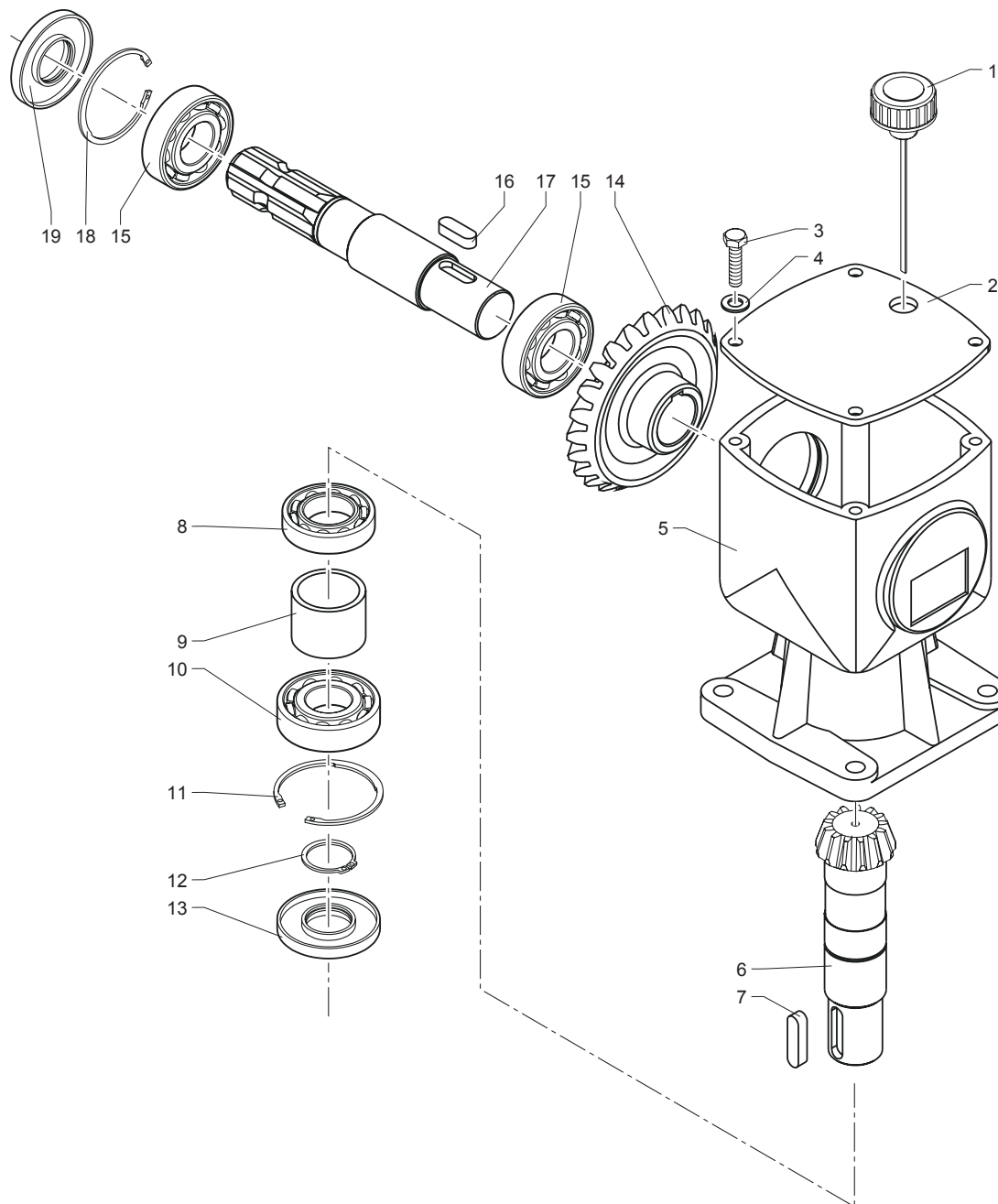

Type: TOSAERBA
Mod.: FA-1200 • FA-1500 • FA-1800
Rev.: 01/2004
Drw: 4/4

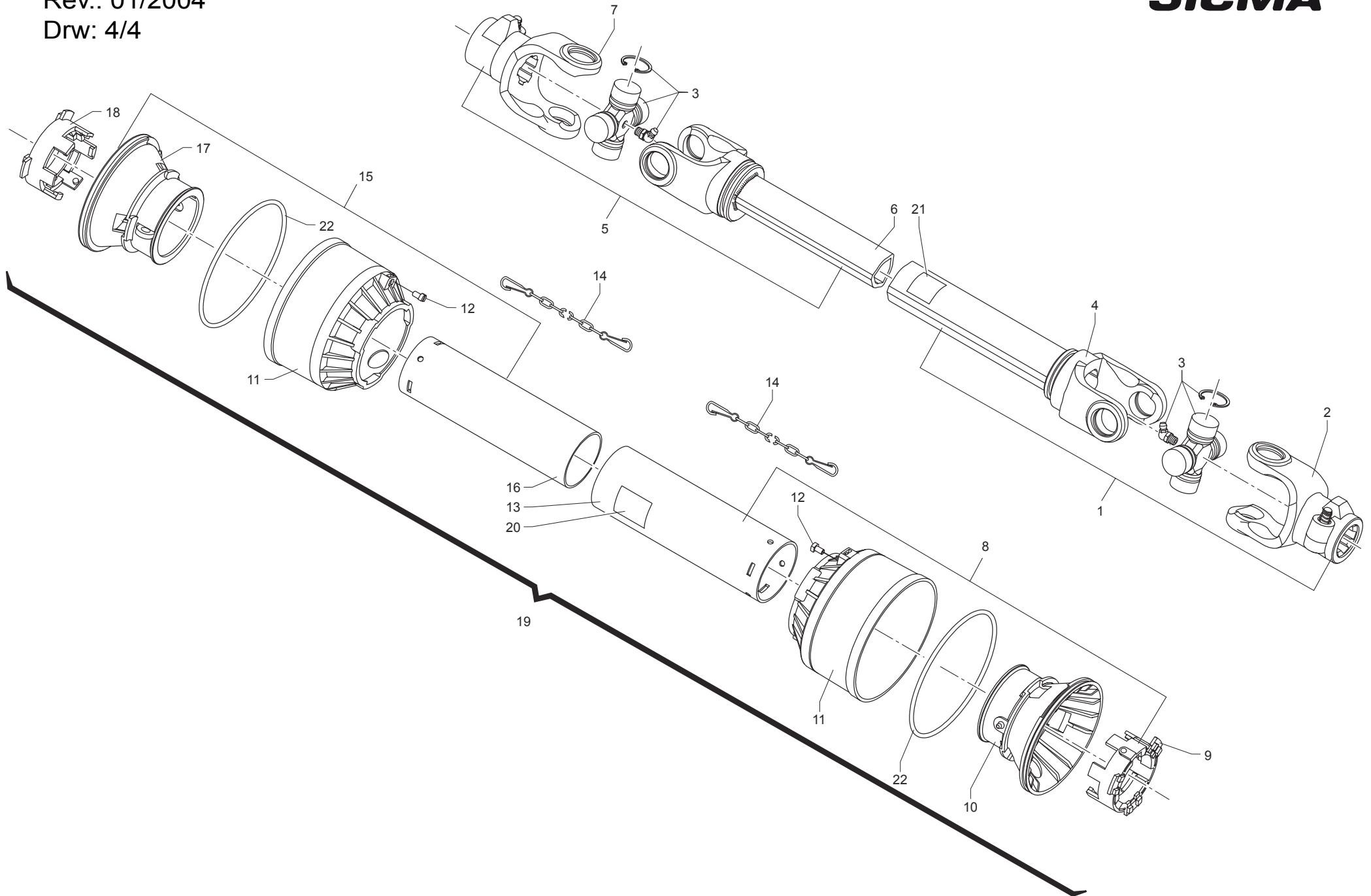

Type: TOSAERBA

Mod.: FA-1200 • FA-1500 • FA-1800

Rev.: 01/2004

Tab.: 1/4

Pag. 1/1

RIF.	CODICE	DENOMINAZIONE	DESCRIPTION	BENENNUNG	DESIGNATION
1	31508016	Vite M8x16 p.g. uni 5739	Screw, M8X16, UNI 5739	Schraube M8X16, UNI 5739	Vis M8X16, UNI 5739
2	34118008	Rondella piana uni6593	Flat washer, UNI 6593	Scheibe UNI 6593	Rondelle UNI 6593
3	33108020	Vite M8x20 p.g. uni 5449	Screw, M8X20, UNI 5449	Schraube M8X20, UNI 5449	Vis M8X20, UNI 5449
4	34108012	Dado autob. M12 pg uni 7474	Self-locking nut M12, UNI 7474	Nutmutter M12, UNI 7474	Ecrou autobloquant M12, UNI 7474
5	1883510	Protezione giunto	Joint cover	Schutz	Protection
6	34120012	Rondella piana uni 6592	Flat washer, UNI 6592	Scheibe UNI 6592	Rondelle UNI 6592
7	80310-00	Moltiplicatore	Amplifier	Übersetzungsgetriebe	Multiplificateur
8	5932707	Piastra tensione cinghie	Belt-tensioning plate	Platte	Plaque
9	34108010	Dado autob. M10 pg uni 7474	Self-locking nut, M10, UNI 7474	Nutmutter M10, UNI 7474	Ecrou autobloquant M10, UNI 7474
10	34120010	Rondella piana uni 6592	Flat washer, UNI 6592	Scheibe UNI 6593	Rondelle UNI 6593
11	34100010	Dado M10 pg uni 5587	Nut, M10, UNI 5587	Mutter M10, UNI 5587	Ecrou M10, UNI 5587
12	5132810	Carter protezione cinghie FA-1200	Belt cover, FA-1200	Riemengahäuse FA-1200	Carter courroies FA-1200
12	5132811	Carter protezione cinghie FA-1500	Belt cover, FA-1500	Riemengahäuse FA-1500	Carter courroies FA-1500
12	5132812	Carter protezione cinghie FA-1800	Belt cover, FA-1800	Riemengahäuse FA-1800	Carter courroies FA-1800
13	31312040	Vite M12x40 p.g. uni 5737	Screw, M12X40, UNI 5737	Schraube M12X40, UNI 5737	Vis M12X40, UNI 5737
14	31510080	Vite M10x80 p.g. uni 5739	Screw, M10x80, UNI 5739	Schraube M10x80, UNI 5739	Vis M10x80, UNI 5739
15	5932710	Supporto moltiplicatore FA-1200	Amplifier support, FA-1200	Halterung FA-1200	Support FA-1200
15	5932711	Supporto moltiplicatore FA-1500	Amplifier support, FA-1500	Halterung FA-1500	Support FA-1500
15	5932724	Supporto moltiplicatore FA-1800	Amplifier support, FA-1800	Halterung FA-1800	Support FA-1800
16	31510025	Vite M10x25 p.g. uni 5739	Screw, M10X25, UNI 5739	Schraube M10X25, UNI 5739	Vis M10X25, UNI 5739
17	34127025	Ghiera autob. M25x1,5	Self-locking ring, M25X1.5	Gewinding M25X1.5	Virole M25X1.5
18	33010030	Vite M10x30 p.g. uni 5731	Screw, M10X30, UNI 5731	Schraube M10X30, UNI 5731	Vis M10X30, UNI 5731
19	34026010	Rosetta schnorr M10	Schnorr washer, M10	Scheibe M10	Rondelle M10
20	5002733	Puleggia condotta lat. spb 110 FA-1200	Side driven pulley, spb 110 FA-1200	Riemenscheibe, spb 110 FA-1200	Poulie, spb 110 FA-1200
20	5002718	Pul. condotta lat. Dp.130 FA-1500 - FA-1800	Side driven pulley, Dp.130 FA-1500 - FA-1800	Riemenscheibe, Dp 130 FA-1500 - FA-1800	Poulie, Dp 130 FA-1500 - FA-1800
21	6722056	Cinghia B56 FA-1200	Belt, B62, FA-1200	Zahnriemen B62, FA-1200	Courroie B62, FA-1200
21	6722068	Cinghia B68 FA-1500	Belt, B68, FA-1500	Zahnriemen B62, FA-1500	Courroie B62, FA-1500
21	6722074	Cinghia B74 FA-1800	Belt, B75, FA-1800	Zahnriemen B62, FA-1800	Courroie B62, FA-1800
22	5002781	Scocca FA-1200	Cover, FA-1200	Gestell FA-1200	Cadre FA-1200
22	5002782	Scocca FA-1500	Cover, FA-1500	Gestell FA-1500	Cadre FA-1500
22	5002783	Scocca FA-1800	Cover, FA-1800	Gestell FA-1800	Cadre FA-1800
23	5002716	Puleggia Motrice Dp.225 FA-1200 - FA-1500	Drive pulley, Dp. 225 FA-1200 - FA-1500	Riemenscheibe Dp. 225 FA-1200 - FA-1500	Poulie conduite Dp. 225 FA-1200 - FA-1500
23	5002715	Puleggia Motrice Dp. 190 FA-1800	Drive pulley, Dp. 190, FA-1800	Riemenscheibe Dp. 225 FA-1800	Poulie conduite Dp. 225 FA-1800
24	5132734	Rondella fissaggio puleggia motrice	Drive pulley anchoring washer	Scheibe	Rondelle
25	5002728	Puleggia condotta cent. spb 110 FA-1200	Central driven pulley, spb 110 FA-1200	Riemenscheibe spb 110 FA-1200	Poulie spb 110 FA-1200
25	5002717	Pul. condotta cent. Dp.130 FA-1500 - FA-1800	Central driven pulley, Dp.130 FA-1500 - FA-1800	Riemenscheibe SPB 160x2	Poulie SPB 160x2
26	34121012	Rondella grower ø 12 uni 1751	Grower washer, ø 12, UNI 1751,	Scheibe ø 12, UNI 1751,	Rondelle ø 12, UNI 1751,
27	31512040	Vite M12x40 pg uni 5739	Screw, M12X40, UNI 5739	Schraube M12X40, UNI 5739	Vis M12X40, UNI 5739
28	5132731	Distanziale	Spacer	Distanzstück	Entretoise
29	6360835	Chiavetta 8x35x7 uni 6604	Key, 8x35x7, UNI 6604	Keil 8x35x7, UNI 6604	Clavette 8x35x7, UNI 6604
30	5202701	Albero condotto porta lame	Blade-holder driven shaft	Welle	Arbre
31	2216205	Cuscinetto 6205 RS	Bearing, 6205 RS	Lager, 6205 RS	Roulement, 6205 RS
32	5002723	Kit fissaggio coltello FA-1200	Blade fixing kit FA-1200	Messerbefestigungssatz FA-1200	Kit de fixation couteau FA-1200
32	5002724	Kit fissaggio coltello FA-1500	Blade fixing kit FA-1500	Messerbefestigungssatz FA-1500	Kit de fixation couteau FA-1500
32	5002725	Kit fissaggio coltello FA-1800	Blade fixing kit FA-1800	Messerbefestigungssatz FA-1800	Kit de fixation couteau FA-1800
33	5532705	Distanziale cuscinetto supporto	Holder bearing spacer	Distanzstück	Entretoise
34	5002714	Supporto coltello	Support	Halterung	Support
35	5362701	Colonna	Stud bolt	Säule	Colonnnette
36	31510025	Vite M10x25 pg uni 5739	Screw, M10x25, UNI 5739	Schraube M8X16, UNI 5739	Vis M8X16, UNI 5739
37	5142701	Distanziale	Spacer	Distanzstück	Entretoise
38	34026018	Rosetta schnorr M18	Schnorr washer, M18	Scheibe M18	Rondelle M18
39	5812701	Lama FA-1200	Blade, FA-1200	Messer, FA-1200	Couteau, FA-1200
39	5812702	Lama FA-1500	Blade, FA-1500	Messer, FA-1500	Couteau, FA-1500
39	5812703	Lama FA-1800	Blade, FA-1800	Messer, FA-1800	Couteau, FA-1800
40	34109018	Dado autob. M18 p.f. uni 7474	Self-locking nut, M18, UNI 7474	Nutmutter, M18, UNI 7474	Ecrou autobloquant, M18, UNI 7474
41	6560008	Ingrassatore a punta M8x1,25	Lubricator, M8X125	Schmiernippel M8X125	Graisseur M8X125
42	5002708	Perno	Pin	Bolzen	Axe
43	5782780	Rullo stabilizzatore	Roller	Rolle	Rouleau
44	5782789	Cuscinetto	Bearing	Lager	Roulement
45	6330814	Spina 8x14	Split pin 8x14	Splint 8x14	Coupille 8x14
46	5002707	Supporto	Support	Halterung	Support
47	31510025	Vite M10x25 PG UNI 5739	Screw M10x25 PG UNI 5739	Schraube M10x25 PG UNI 5739	Vis M10x25 PG UNI 5739
48	31512040	Vite M12x40 PG UNI 5739	Screw M12x40 PG UNI 5739	Schraube M12x40 PG UNI 5739	Vis M12x40 PG UNI 5739
49	34120012	Rondella piana ø 12 UNI 6593	Washer ø 12 UNI 6593	Scheibe ø 12 UNI 6593	Rondelle ø 12 UNI 6593
50	34121012	Rondella piana ø 12 UNI 1751	Washer ø 12 UNI 1751	Scheibe ø 12 UNI 1751	Rondelle ø 12 UNI 1751
51	34102012	Dado M 12 PG UNI 5587	Nut M 12 PG UNI 5587	Mutter M 12 PG UNI 5587	Ecrou M 12 PG UNI 5587
52	34121010	Rondella piana ø 10 UNI 1751	Washer ø 10 UNI 1751	Scheibe ø 10 UNI 1751	Rondelle ø 10 UNI 1751
53	34118010	Rondella piana ø 10x24 UNI 6593	Washer ø 10x24 UNI 6593	Scheibe ø 10x24 UNI 6593	Rondelle ø 10x24 UNI 6593
54	5812712	Lama FA-1200 (mulching)	Blade, FA-1200 (mulching)	Messer, FA-1200 (mulching)	Couteau, FA-1200 (mulching)
54	5812713	Lama FA-1500 (mulching)	Blade, FA-1500 (mulching)	Messer, FA-1500 (mulching)	Couteau, FA-1500 (mulching)
54	5812714	Lama FA-1800 (mulching)	Blade, FA-1800 (mulching)	Messer, FA-1800 (mulching)	Couteau, FA-1800 (mulching)

Type: TOSAERBA

Mod.: FA-1200 • FA-1500 • FA-1800

Rev.: 01/2004

Tab.: 2/4

Pag. 1/1

RIF.	CODICE	DENOMINAZIONE	DESCRIPTION	BENENNUNG	DESIGNATION
1	6331046	Spina a scatto	Release pin	Klappsplint	Goujon de sûreté
2	5532714	Boccola distanziale 3° punto	Spacer bushing, 3rd point	Buchse	Douille
3	31312130	Vite M12x130 p.g. uni 5737	Screw, M12X130, UNI 5737	Schraube M12X130, UNI 5737	Vis M12X130, UNI 5737
4	5302706	Perno 3° punto	Pin, 3rd point	Bolzen	Axe
5	5832713	Staffa, 3° punto superiore	Bracket	Pratze	Bride
6	5832720	Braccio attacco 3° punto FA 1200	Coupling arm, 3rd point FA 1200	Arm FA 1200	Bras FA 1200
6	5832714	Braccio attacco 3° p. FA1500 - FA1800	Coupling arm, 3rd point FA1500-FA1800	Arm FA 1500 - FA 1800	Bras FA 1500 - FA 1800
7	5832721	Braccio tirante 3° punto FA 1200	Tie-rod arm, 3rd point FA 1200	Arm FA 1200	Bras FA 1200
7	5832716	Braccio tirante 3° punto FA 1500	Tie-rod arm, 3rd point FA 1500	Arm FA 1500	Bras FA 1500
7	5832717	Braccio tirante 3° punto FA 1800	Tie-rod arm, 3rd point FA 1800	Arm FA 1800	Bras FA 1800
8	34106012	Dado autob. M12 p.g. alto	Self-locking nut, M12, high	Nutmutter M12	Ecrou autobloquant M12
9	31512035	Vite M12x35 p.g. uni 5739	Screw, M12X35, UNI 6739	Schraube M12X35, UNI 6739	Vis M12X35, UNI 6739
10	5302704	Perno braccio attacco inferiore	Lower coupling arm pin	Bolzen	Axe
11	5302705	Perno 3° punto inferiore	Pin, 3rd lower point	Bolzen	Axe
12	31312065	Vite M12x65 p.g. uni 5737	Screw, M12X65, UNI 5737	Schraube M12X65, UNI 5737	Vis M12X65, UNI 5737
13	5002785	Braccio supporto ruota Dx FA 1200	Wheel holding arm, RH, FA 1200	Arm FA 1200	Bras FA 1200
13	5002786	Braccio supporto ruota Dx FA 1500	Wheel holding arm, RH, FA 1500	Arm FA 1500	Bras FA 1500
13	5002787	Braccio supporto ruota Dx FA 1800	Wheel holding arm, RH, FA 1800	Arm FA 1800	Bras FA 1800
14	5002713	Braccio 3° punto inferiore	Arm, 3rd lower point	Arm	Bras
15	34118012	Rondella piana uni 6593	Flat washer, UNI 6593	Scheibe UNI 6593	Rondelle UNI 6593
16	5532709	Distanziale altezza 6 mm	Spacer, height: 6 mm	Distanzstück	Entretoise
17	5532708	Distanziale altezza 12,5 mm	Spacer, height: 12.5 mm	Distanzstück	Entretoise
18	5532704	Distanziale altezza 16 mm	Spacer, height: 16 mm	Distanzstück	Entretoise
19	5532707	Distanziale altezza 25 mm	Spacer, height: 25 mm	Distanzstück	Entretoise
20	5532706	Distanziale altezza 32 mm	Spacer, height: 32 mm	Distanzstück	Entretoise
21	6560008	Ingrassatore a punta M8	Lubricator, M8	Schmiernippel M8	Graisseur M8
22	5132731	Distanziale	Spacer	Distanzstück	Entretoise
23	5002719	Forcella per ruota	Wheel fork	Gabel	Fourche
24	6331056	Spina a scatto	Release pin	Klappsplint	Goujon de sûreté
25	5002730	Kit ruota con pneumatico ad aria	Wheel kit	Rädersatz	Kit roue
25	5002737	Kit ruota con pneumatico pieno	Wheel kit	Rädersatz	Kit roue
26	5532712	Tubo fissaggio ruota	Wheel mounting pipe	Schlauch	Tuyau
27	5532713	Distanziale pneumatico ad aria	Short, air tube	Distanzstück	Entretoise
27	5532716	Distanziale pneumatico pieno	Short solid tire	Distanzstück	Entretoise
28	31312130	Vite M12x130 p.g. uni 5737	Screw, M12X130, UNI 5737	Schraube M12X130, UNI 5737	Vis M12X130, UNI 5737
29	6611405	Pneumatico 11x4.00-5 cam. d'aria	Wheel, 11x4.00-5	Rad, 11x4.00-5	Roue, 11x4.00-5
29	6602739	Pneumatico pieno ø 250x85	Wheel ø250x85	Rad ø250x85	Roue ø250x85
30	ETX40058-2459	Giunto, TX-4 580-1024010x2	Joint, TX-4 580-1024010x2	Kupplung, TX-4 580-1024010x2	Joint, TX-4 580-1024010x2
31	34120012	Rondella piana uni 6592	Flat washer, UNI 6592	Scheibe	Rondelle
32	5782790	Cuscinetto iglodur M250	Bearing iglodur M250	Lager	Roulement
33	6351004	Spina a "R" ø 4	Split pin ø 4	Splint ø 4	Coupille ø 4

RIF.	CODICE	DENOMINAZIONE	DESCRIPTION	BENENNUNG	DESIGNATION
1	25210-01	Tappo livello olio	Oil level plug	Auspuffpropfen	Bouchon
2	11310-01	Coperchio carter	Cover	Deckel	Couvercle
3	31508020	Vite M8x20 p.g. uni 5739	Screw, M8X20, UNI 5739	Schraube M8X20, UNI 5739	Vis M8X20, UNI 5739
4	34026008	Rosetta Schnorr M8	Washer, Schnorr, M8	Scheibe M8	Rondelle M8
5	16510-01	Carter coppia conica	over, bevel gear pair	Gehäuse	Carter
6	17210-03	Pignone conico Z12	Taper pinion Z12	Kegelritzel Z 12	Pignon conique Z 12
7	6361040	Chiavetta 10x40x8 uni 6604	Key, 10X40X8, UNI 6604	Keil 10X40X8, UNI 6604	Clavette 10X40X8, UNI 6604
8	2106008	Cuscinetto 6008	Bearing, 6008	Lager 6008	Roulement 6008
9	15310-01	Distanziale pignone	Pinion spacer	Distanzstück	Entretoise
10	2106208	Cuscinetto 6208	Bearing 6208	Lager 6208	Roulement 6208
11	6310080	Seeger per interno	Inner Seeger-clip	Seegersicherung	Bague d'arrêt
12	6320040	Seeger per esterno	Outer Seeger-clip	Seegersicherung	Bague d'arrêt
13	6204080	Paraolio	Oil seal	Oelabdichtung	Pare-huile
14	17210-02	Corona conica Z34	Ring bevel gear, Z34	Kegelradkranz, Z34	Couronne conique, Z34
15	2106207	Cuscinetto 6207	Bearing 6207	Lager 6207	Roulement 6207
16	6361030	Chiavetta 10x30x8 uni 6604	Key 10x30x8, UNI 6604	Keil 10x30x8, UNI 6604	Clavette 10x30x8, UNI 6604
17	12010-01	Albero corona	Ring shaft	Welle	Arbre
18	6310072	Seeger per interno	Inner Seeger-clip	Seegersicherung	Bague d'arrêt
19	6203572	Paraolio ø 35x72x10 pp	Oil seal, ø 35x72x10	Oelabdichtung ø 35x72x10	Pare-huile ø 35x72x10

Type: TOSAERBA

Mod.: FA-1200 • FA-1500 • FA-1800

Rev.: 01/2004

Tab.: 4/4

Pag. 1/1

RIF.	CODICE	DENOMINAZIONE	DESCRIPTION	BENENNUNG	DESIGNATION
1	TX40900-0001	Semialbero esterno	Half outer shaft	Halbwelle außen	Demi-essieu extérieur
2	1024010	Forcella esterna (lato trattore)	Yoke assembly (tractor end)	Gabel	Fourche
3	1004010	Compressivo crociera	Cross assembly	Gruppe Gelenkkreuz	Ensemble croisière
4	1944040N	Compressivo telescopico esterno	Outside tube with yoke	Gruppe Teleskoprohr außen	Ensemble télescopique extérieur
5	TX40910-0001	Semialbero interno	Half inner shaft	Halbwelle innen	Demi-essieu intérieur
6	1954042N	Compressivo telescopico interno	Inside tube with yoke	Gruppe Teleskoprohr innen	Ensemble télescopique intérieur
7	1024010	Forcella esterna (lato attrezzo)	Yoke assembly (implement end)	Gabel	Fourche
8	90SX4038	Semiprotezione esterna	Half outer protection	Abdeckungsteil außen	Pièce de protection extérieure
9	1784210	Ghiera tubo esterno	Tube bearing	Gewinding	Virole
10	1784201	Calotta tubo esterno	Outer tube rigid cone	Kappe Außenrohr	Calotte tube extérieur
11	1784203	Cuffia standard	Soft standard cone	Standardmanschette	Coiffe standard
12	1784212	Perno fermo rotazione	Pin for stop rotation	Bolzen	Axe
13	1773038	Tubo esterno	Outer tube	Schlauch	Tuyau
14	1006065	Catena antirotazione	Antirotation chain	Kette	Chaîne
15	90XS4038	Semiprotezione interna	Half inner protection	Abdeckungsteil innen	Pièce de protection intérieure
16	1872038	Tubo interno	Inner tube	Schlauch	Tuyau
17	1784202	Calotta tubo interno	Inner tube rigid cone	Kappe Innenrohr	Calotte tube intérieur
18	1784211	Ghiera tubo interno	Tube bearing	Gewinding	Virole
19	90SS4038	Protezione completa	Complete protection	Schutz	Protection
20	1140001	Adesivo esterno	Outer decal	Aufkleber außen	Etiquette extérieure
21	1140003	Adesivo interno	Inner decal	Aufkleber innen	Etiquette intérieure
22	1213233	Anello di rinforzo	Stiffening ring	Ringe	Anneau